



AST 7008

RETAIL CASH SYSTEM

AST 7008H // AST 7008HB // AST 7008S // AST 7008C // AST 7008CB

AST 7008



AST 7008 represents the perfect combination between a TCR and a deposit unit. Perfect for back-office and retail applications, it is featured by a high capacity (up to 5.600 recycled banknotes + 4.000 banknotes in the heat-sealing disposable bag or 10.000 banknotes in the canvas bag).

- **In retail applications it is the perfect tool for the preparation of the teller's shift start kit and the shift end deposit**
- It can be interfaced with coin handling devices
- Availability of different bag typologies such as the high capacity canvas bag, the disposable heat-sealing bag and the disposable **heat-sealing stacking bag**
- **Thanks to the "bundling" device, possibility to bundle the banknotes before they get into the bags**
- **Availability of the receipt removable by the CIT in the heat-sealing bag**
- Possibility of multicurrency operation
- Banknotes' recognition is performed by CIMA's sensor **BV 5000** employing all the most advanced technologies: magnetic, infrared, fluorescence, ultraviolet, visible light. It's possible to have both the authenticity recognition function and the fitness feature; in both cases all solutions are certified by the European Central Bank
- **The maintenance footprint is extremely compact thanks to the modular system with two separate internal frames**
- If the bank's requirements had to change over time and it was necessary to handle big amounts of banknotes in recycling, **AST 7008** can be converted into **AST 7016** thanks to the **plug & play** module, which allows to replace the frame carrying the heat-sealing bag with an 8-drum frame
- **Flawless fitness management, as the worn out banknotes are directly stored into the bag**
- **The banknotes handled by the drums are automatically stored into the bag: this process automation reducing the manual handling of**

money helps to prevent and minimize human mistakes

- **In the Heat version the safe can be opened just once the bag has self-sealed**
- Remarkable reduction of the teller's working time both in deposit and withdrawal stages (high transaction speed: up to 6 banknotes/second)
- Real time update of balances and cash in hands
- Possibility to return the last deposit made
- It considerably reduces the cash in hand within the branch
- Software and hardware for the management of alarms and security locks
- Possibility of remote management through the C-Link platform

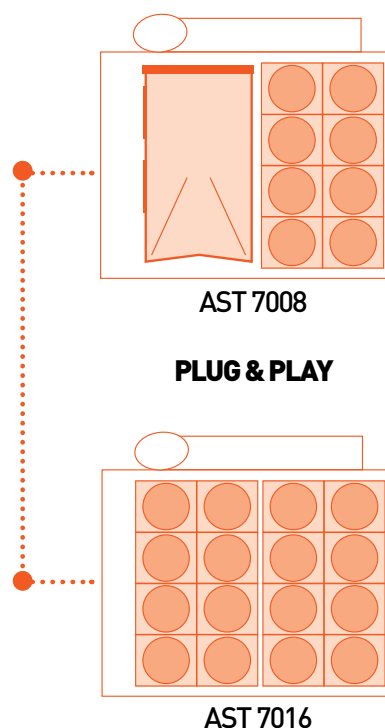

TECHNICAL SPECIFICATIONS

SAFE AVAILABLE IN

12 mm (UL 291), CEN L, CEN III, and CEN IV

WEIGHT

From 450 kg to 740 kg according to the configuration

ELECTRICAL CHARACTERISTICS

Voltage 90 – 240 V AC
Frequency 50 – 60 Hz
Power input 600 W

CONNECTIONS

RS232 serial port
or USB 1.0 port or ethernet

NUMBER OF DRUMS HANDLED

Up to 8

DEPOSIT CAPACITY IN RECYCLING

Up to 700 banknotes each drum

CAPACITY OF BAG DEPOSIT

Up to 10.000 banknotes with canvas bag
Up to 4.000 banknotes with heat-sealing bag
Up to 3.000 with stacking bag

- These capacities are the same also when combined with the bundling

HANDLING OF DRUMS

- Storage by single denomination with recycling function
- Multi-denomination storage with stocking and recycling function
- Drums' flexibility

BANKNOTES DETECTOR

Authenticity ECB certified
Possibility of multi-currency operation
Fitness ECB certified

DEPOSIT AND WITHDRAWAL SPEED

Up to 6 banknotes per second

SIZE OF THE BANKNOTES HANDLED (standard configuration)

Length
from 100 mm to 190 mm
Width
from 60 mm to 82 mm

SECURITY

- Handling of 20 time bands
- 3 different alarm outputs
- Timed handling of locks



info@cimaspa.it

CASH DEPOSIT AND RECYCLING SYSTEM



DIMENSIONS

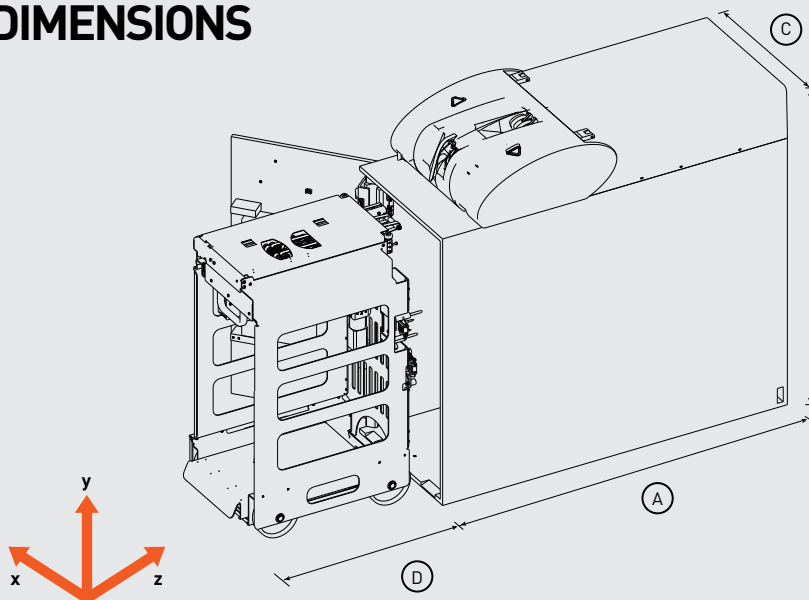

- (A) 1055mm - UL291
1165mm - CEN L, CEN III, and CEN IV
- (B) 957mm - UL291
1012mm - CEN L, CEN III, and CEN IV
- (C) 440mm - UL291
500mm - CEN L, CEN III, and CEN IV
- (D) 570mm - UL291
620mm - CEN III, CEN L and CEN IV

Specifications can be subject to change without notice.

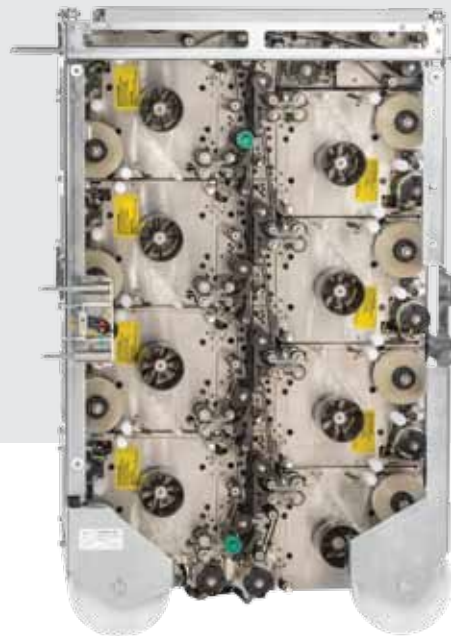

+ ...

AST 7008H

AST 7008H = RECYCLING + HEAT SEALING BAG



AST 7008HB

AST 7008 HB = RECYCLING + HEAT SEALING BAG + BUNDLING



AST 7008S

AST 7008 S = RECYCLING + STACKING BAG

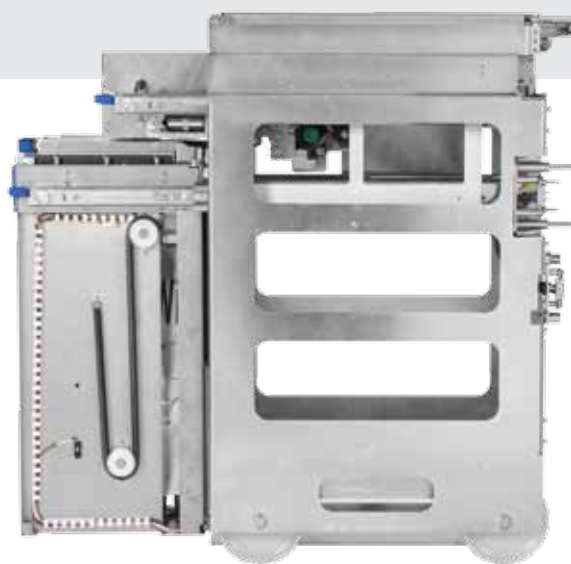
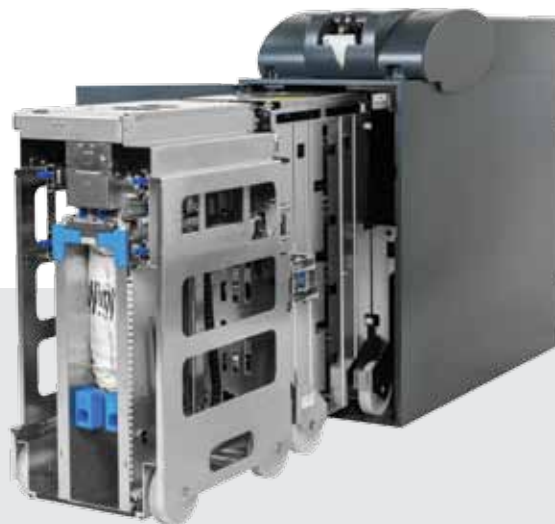



CIMA S.p.A. - P.IVA IT03536420361
Via Di Mezzo 2/4 - 41037 Mirandola (Modena) - Italy
Tel. +39 0535 418611 - Fax +39 0535 23062
www.cimaspa.it // info@cimaspa.it